

5275

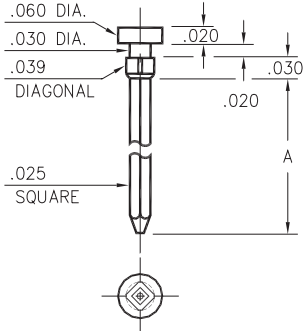

Basic Part Number	# of Wraps	Wrapost Length A
5275-1	1	.370
5275-2	2	.470
5275-3	3	.610

5275-X-05-XX-00-00-01-0
Square press-fit in .035 plated thru hole

1010 ⇒ 1012/1020 ⇒ 1022

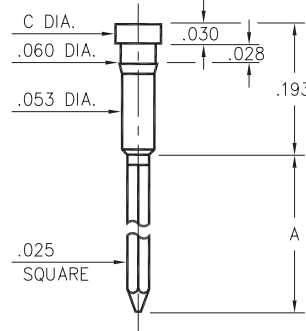

Basic Part Number	# of Wraps	Wrapost Length A	Head Dia. C
1012-1	1	.260	.072
1011-2	2	.360	
1010-3	3	.500	
1022-1	1	.260	.062
1021-2	2	.360	
1020-3	3	.500	

10XX-X-05-XX-00-00-01-0
Press-fit in .057 mounting hole

1215

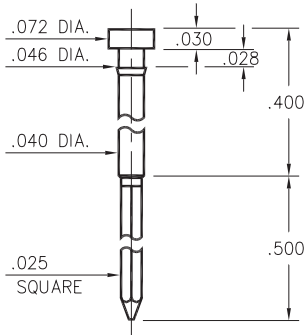

1215-3-05-XX-00-00-01-0
Press-fit in .043 mounting hole

1124

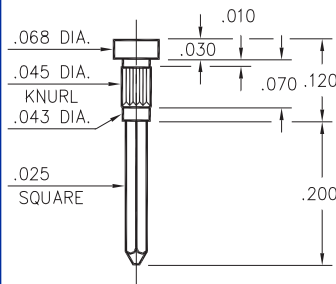

1124-0-05-XX-00-00-01-0
Press-fit in .043 mounting hole

1210

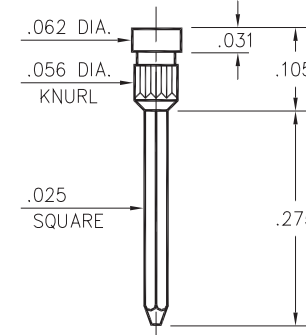

1210-0-05-XX-00-00-01-0
Press-fit in .053 mounting hole

1222

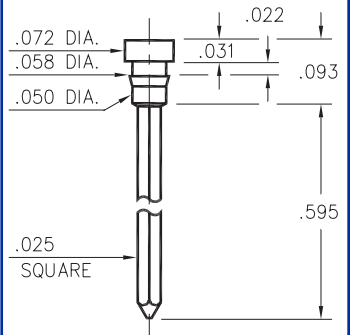

1222-0-05-XX-00-00-01-0
Press-fit in .055 mounting hole

1221

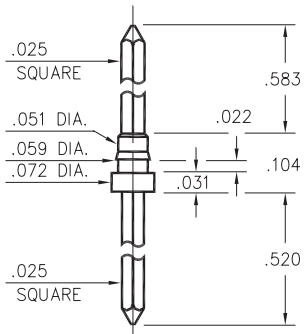

1221-0-05-XX-00-00-01-0
Press-fit in .056 mounting hole

1110

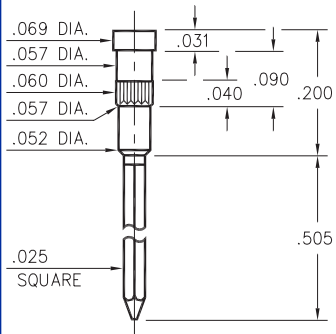

1110-3-05-XX-00-00-01-0
Press-fit in .057 mounting hole

1094

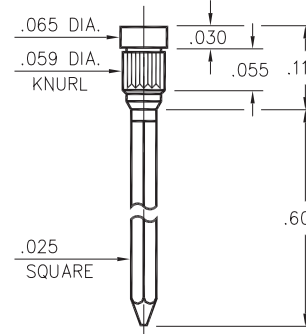

1094-0-05-XX-00-00-01-0
Press-fit in .056 mounting hole

SPECIFICATIONS

PIN MATERIAL:
Brass Alloy 360, 1/2 Hard

DIMENSION IN INCHES
TOLERANCES ON:
LENGTHS: ±.005
DIAMETERS: ±.002
ANGLES: ± 2°

ORDER CODE: XXXX - X - 05 - XX - 00 - 00 - 01 - 0

BASIC PART #

SPECIFY PIN FINISH:
01 200µ" TIN/LEAD OVER NICKEL
80 200µ" TIN OVER NICKEL
15 10µ" GOLD OVER NICKEL
21 20µ" GOLD OVER NICKEL

